

## GY-271 Kompassmodul Kompass Magnet Sensor Datenblatt

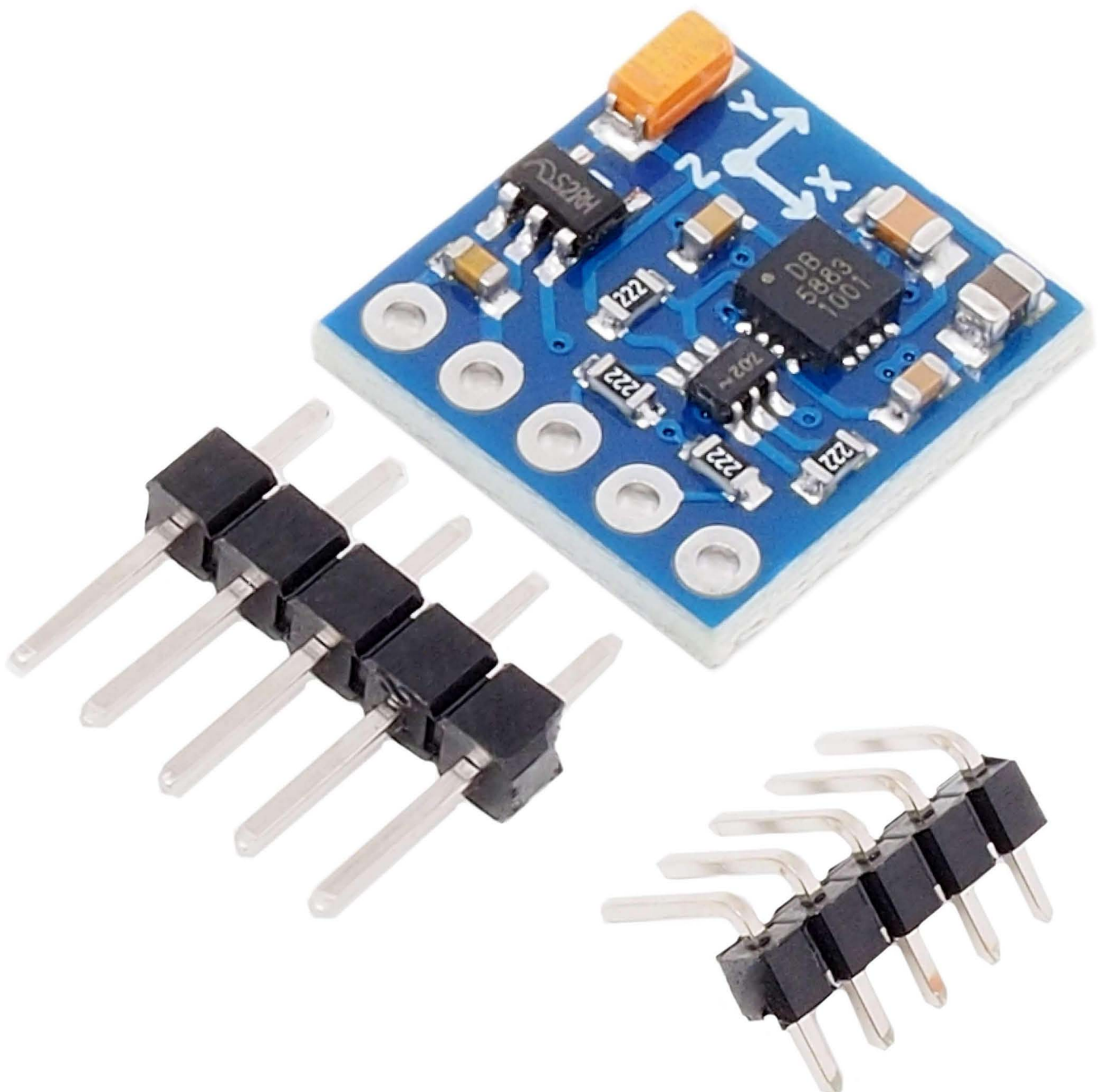

**Contents:**

- 1. Overview**
- 2. Features**
- 3. Benefit**
- 4. Internal Schematic Diagram**
- 5. Specifications and I/O Characteristics**
- 6. Package Pin Configurations**
- 7. External Connection**
- 8. Basic Device Operation**
- 9. Modes Of Operation**
- 10. Application Examples**
- 11. I<sup>2</sup>C Communication Protocol**
- 12. Registers**
- 13. Caution**

## 1. Overview

The QMC5883L is a multi-chip three-axis magnetic sensor. This surface -mount, small sized chip has integrated magnetic sensors with signal condition ASIC, targeted for high precision applications such as compassing, navigation and gaming in drone, robot, mobile and personal hand-held devices. The QMC5883L is based on high resolution, magneto-resistive technology licensed from Honeywell AMR technology. Along with custom-designed 16-bit ADC ASIC, it offers the advantages of low noise, high accuracy, low power consumption, offset cancellation and temperature compensation. QMC5883L enables 1° to 2° compass heading accuracy. The I<sup>2</sup>C serial bus allows for easy interface.

The QMC5883L is in a 3 mm x 3 mm x 0.9 mm surface mount 16-pin land grid array (LGA) package.

## 2. Features

- 3-Axis Magneto-Resistive Sensors in a 3 mm x 3 mm x 0.9 mm Land Grid Array Package (LGA), guaranteed to operate over an extended temperature range of -40 °C to +85 °C
- 16 Bit ADC With Low Noise AMR Sensors Achieves 5 Milli-Gauss Field Resolution
- Wide Magnetic Field Range (±8 Gauss)
- Temperature Compensated Data Output and Temperature Output
- I<sup>2</sup>C Interface with Standard and Fast Modes
- Wide Range Operation Voltage (2.16V To 3.6V) and Low Power Consumption (75µA)
- Lead Free Package Construction
- Software And Algorithm Support Available

### 3. Benefit

- Small Size for Highly Integrated Products. Signals Have Been Digitized And Calibrated
- Enables 1° To 2° Degree Compass Heading Accuracy , Allows for Navigation and LBS Applications
- Maximizes Sensor’s Full Dynamic Range and Resolution
- Automatically Maintains Sensor’s Sensitivity Under Wide Operating Temperature Range
- High-Speed Interfaces for Fast Data Communications. Maximum 200Hz Data Output Rate
- Compatible with Battery Powered Applications
- RoHS Compliance
- Compassing Heading, Hard Iron, Soft Iron, and Auto Calibration Libraries Available

### 4. Internal Schematic Diagram

#### 4.1 Internal Schematic Diagram

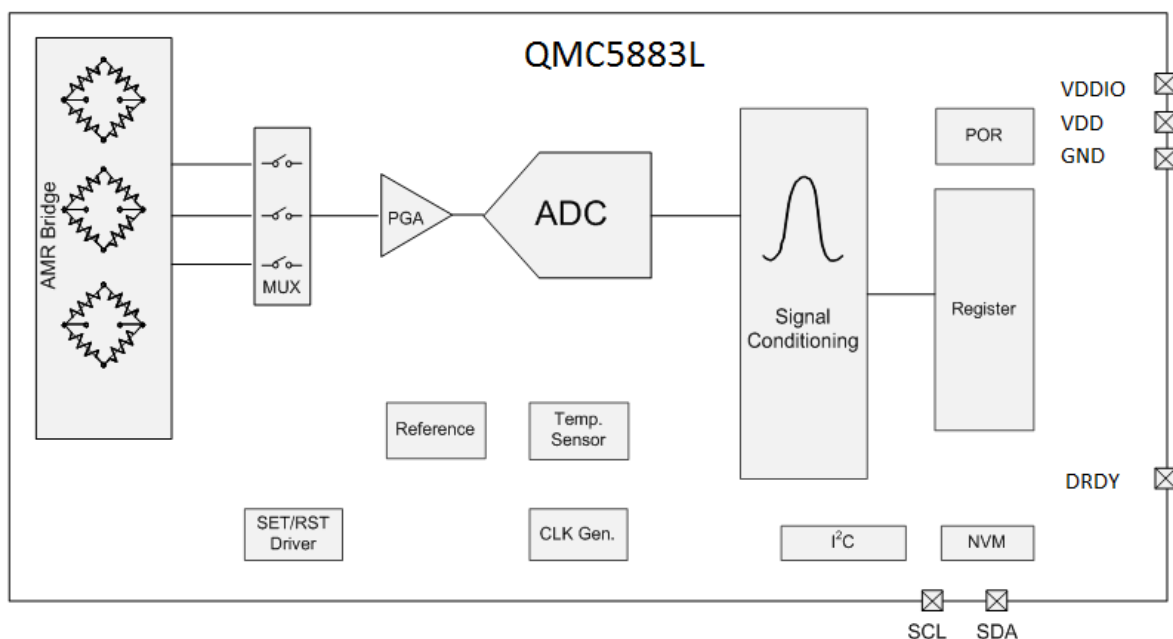

Figure 1. Block Diagram

**Table 1. Block Function**

| <b>Block</b>        | <b>Function</b>  |
|---------------------|--|
| AMR Bridge          | 3 axis magnetic sensor   |
| MUX                 | Multiplexer for sensor channels  |
| PGA                 | Programmable gain amplifier for sensor signals   |
| ADC                 | 16 bit Analog-to-Digital converter   |
| Signal Conditioning | Digital blocks for magnetic signal calibration and compensation                          |
| I <sup>2</sup> C    | Interface logic data I/O   |
| NVM                 | Non-Volatile memory for calibrated parameters  |
| SET/RST Driver      | Internal driver to initialize magnetic sensor  |
| Reference           | Voltage/Current reference for internal biasing   |
| Clock Gen.          | Internal oscillator for internal operation   |
| POR                 | Power on reset   |
| Temperature Sensor  | Temperature sensor for internal sensitivity /offset compensation, and temperature output |

### 5. Specifications and I/O Characteristics

#### 5.1 Product Specifications

Table 2. Specifications (\* Tested and specified at 25°C except stated otherwise.)

| Parameter                         | Conditions                                       | Min         | Typ     | Max | Unit         |
|-----------------------------------|--|-------------|---------|-----|--------------|
| Supply Voltage                    | VDD  | 2.16        |         | 3.6 | V            |
| I/O Voltage                       | VDDIO  | 1.65        |         | 3.6 | V            |
| Standby Current                   | Total Current on VDD and VDDIO                   |             | 3       |     | µA           |
| Continuous Mode Current           | Low/High Power Mode (OSR=64 or 512)              | ODR = 10Hz  | 75/100  |     | µA           |
|                                   |  | ODR = 50Hz  | 150/250 |     | µA           |
|                                   |  | ODR = 100Hz | 250/450 |     | µA           |
|                                   |  | ODR = 200Hz | 450/850 |     | µA           |
| Peak Current in Active State      | Peak Current on VDD and VDDIO During Measurement |             | 2.6     |     | mA           |
| Sensor Field Range                | Full Scale                                       | -8          |         | +8  | Gauss        |
| Dynamic Output Field Range        | Programmable with 2 options                      | ±2          |         | ±8  | Gauss        |
| Sensitivity <sup>[1]</sup>        | Field Range = ±2G                                |             | 12000   |     | LSB/G        |
|                                   | Field Range = ±8G                                |             | 3000    |     | LSB/G        |
| Linearity (Best fit linear curve) | Field Range = ±2G                                |             | 0.1     |     | %FS          |
| Hysteresis                        | All Ranges                                       |             | 0.3     |     | %FS          |
| Cross Axis Sensitivity            | Cross field = 1 Gauss, Happlied = ±2 Gauss       |             | 0.1     |     | %/G          |
| Offset                            |  |             | ±10     |     | mG           |
| Sensitivity Tempco                | Ta = -40°C ~85°C                                 |             | ±0.05   |     | %/°C         |
| Temperature Sensor Sensitivity    | Ta = -40°C ~85°C                                 |             | 100     |     | LSB/°C       |
| Digital Resolution                | Change with Gain                                 | 0.1         |         | 1.0 | mGauss       |
| Field Resolution                  | Standard deviation 100 Data, FS ±2G              |             | 5       |     | mGauss       |
| Output Data Rate                  | Programmable. 10Hz/50Hz/100Hz/200Hz              | 10          |         | 200 | Samples /sec |
| X-Y-Z Orthogonality               | Sensitivity Directions                           |             | 90±1    |     | degree       |
| Operating Temperature             |  | -40         |         | 85  | °C           |
| ESD                               | HB Model   | 2000        |         |     | V            |
|                                   | Machine Model                                    | 200         |         |     |              |

Note [1]: Sensitivity is calibrated at zero field, it is slightly decreased at high fields.

## 5.2 Absolute Maximum Ratings

**Table 3. Absolute Maximum Ratings (Tested at 25°C except stated otherwise.)**

| Parameter                                  | MIN.                           | MAX.  | Units |
|--|--------------------------------|-------|-------|
| VDDIO                                      | -0.3                           | 5.4   | V     |
| VDD  | -0.3                           | 5.4   | V     |
| Storage Temperature                        | -40                            | 125   | °C    |
| Exposed to Magnetic Field (all directions) |                                | 50000 | Gauss |
| Reflow Classification                      | MSL 3, 260 °C Peak Temperature |       |       |

## 5.3 I/O Characteristics

**Table 4. I/O Characteristics**

| Parameter                  | Symbol           | Pin      | Condition   | Min.          | TYP. | Max.          | Unit |
|----------------------------|------------------|----------|---|---------------|------|---------------|------|
| Voltage Input High Level 1 | V <sub>IH1</sub> | SDA, SCL |   | 0.7*VD<br>DIO |      | VDDIO+<br>0.3 | V    |
| Voltage Input Low Level 1  | V <sub>IL1</sub> | SDA, SCL |   | -0.3          |      | 0.3*VD<br>DIO | V    |
| Voltage Output High Level  | V <sub>OH</sub>  | INT      | Output Current<br>≥-100uA                                     | 0.8*VD<br>DIO |      |               | V    |
| Voltage Output Low Level   | V <sub>OL</sub>  | INT, SDA | Output Current<br>≤100uA(INT)<br>Output Current<br>≤1mA (SDA) |               |      | 0.2*VD<br>DIO | V    |

## 6. Package Pin Configurations

### 6.1 Package 3-D View

Arrow indicates direction of magnetic field that generates a positive output reading in normal measurement configuration.

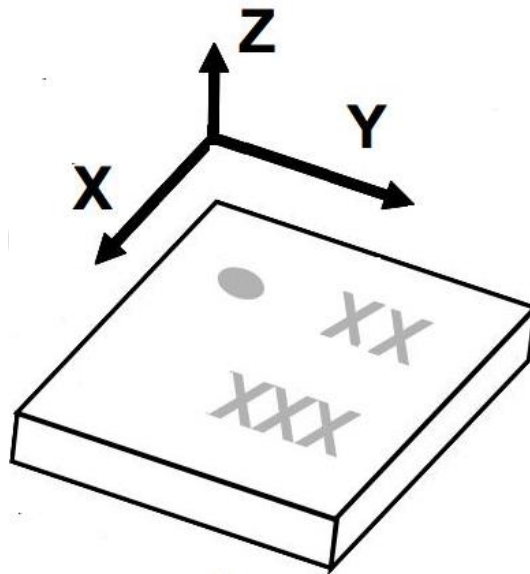
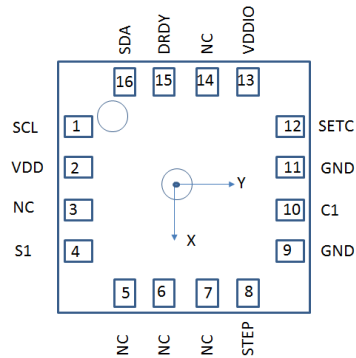

Figure 2. Package 3-D View

Table 5. Pin Configurations

| PIN No. | PIN NAME | Function   |
|---------|----------|--|
| 1       | SCL      | Serial Clock – I2C Master/Slave Clock  |
| 2       | VDD      | Power Supply (2.16V to 3.6V)   |
| 3       | NC       | Not to be Connected  |
| 4       | S1       | Tie to VDDIO   |
| 5       | NC       | Not to be Connected  |
| 6       | NC       | Not to be Connected  |
| 7       | NC       | Not to be Connected  |
| 8       | SETP     | Set/Reset Strap Positive – S/R Capacitor (C2) Connection                             |
| 9       | GND      | Supply Ground  |
| 10      | C1       | Reservoir Capacitor (C1) Connection  |
| 11      | GND      | Supply Ground  |
| 12      | SETC     | S/R Capacitor (C2) Connection – Driver Side  |
| 13      | VDDIO    | IO Power Supply (1.71V to VDD)   |
| 14      | NC       | Not to be Connected  |
| 15      | DRDY     | Data Ready, Interrupt Pin. Default low. Data ready high until data register is read. |
| 16      | SDA      | Serial Data – I2C Master/Slave Data  |





Top View (looking through)

### 6.2 Package Outlines

#### 6.2.1 Package Type LGA (Land Grid Array)

#### 6.2.2 Package Size: 3mm (Length)\* 3mm (Width)\* 0.9mm (Height)

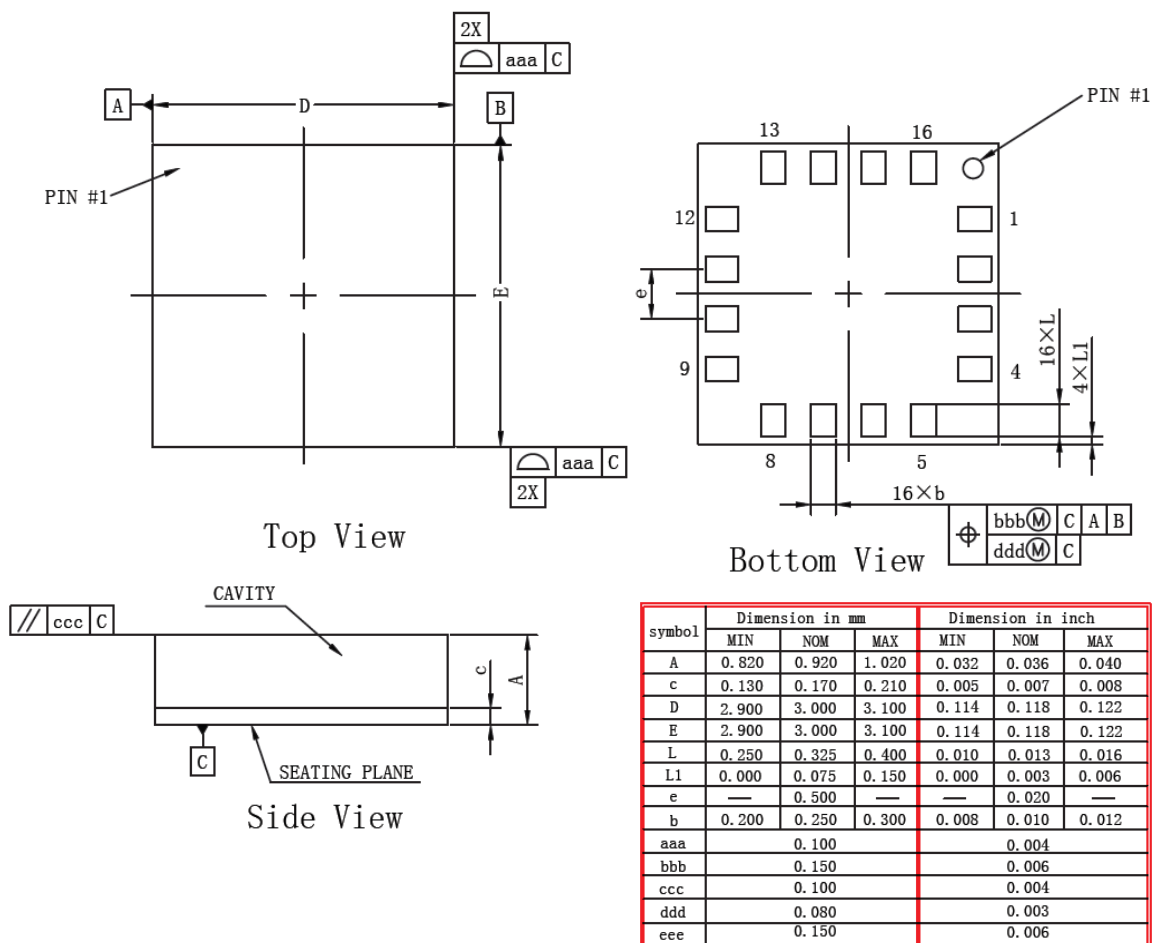

Figure 3. Package Size

### 6.2.3 Marking

Tracking code:

Text1: D Fixed code, X System generated for Customer type 9th bit

Text2: System generated for front 2 of Customer Batch number

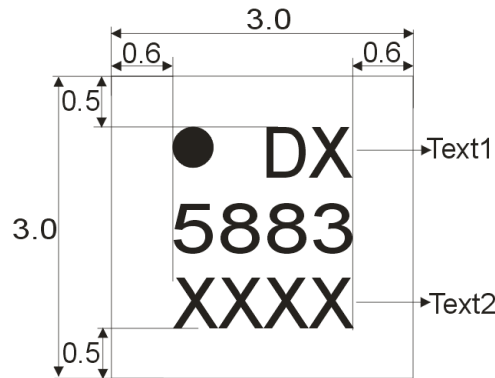

Figure 4. Chip Marking

## 7. External Connection

### 7.1 Dual Supply Connection

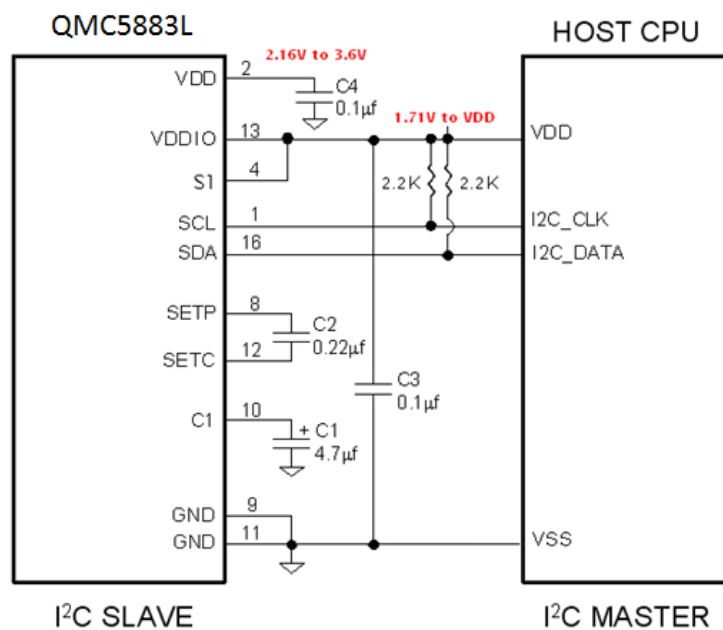
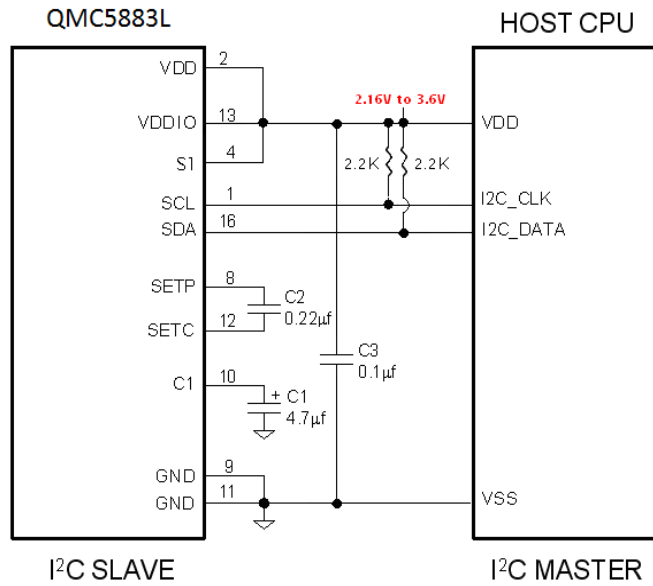

Figure 5. Dual Supply Connection

### 7.2 Single Supply connection



**Figure 6. Single Supply Connection**

### 7.3 Mounting Considerations

The following is the recommend printed circuit board (PCB) footprint for the QMC5883L. Due to the fine pitch of the pads, the footprint should be properly centered in the PCB.

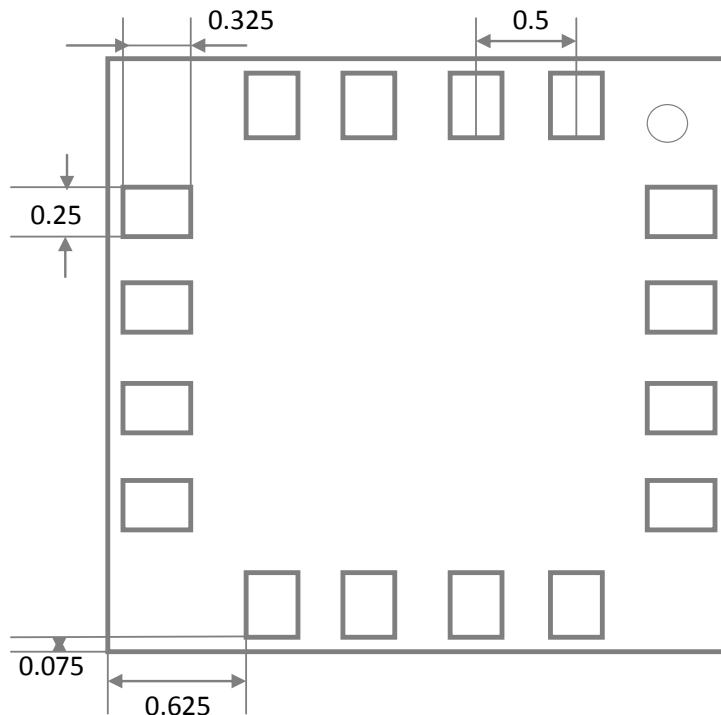

**Figure 7. QMC5883L PCB footprint**

## 7.4 Layout Considerations

Besides keeping all components that may contain ferrous materials (nickel, etc.) away from the sensor on both sides of the PCB, it is also recommended that there is no conducting copper line under/near the sensor in any of the PCB layers.

### 7.4.1 Solder Paste

A 4 mil stencil and 100% paste coverage is recommended for the electrical contact pads.

### 7.4.2 Reflow Assembly

This device is classified as MSL 3 with 260°C peak reflow temperature. As specified by JEDEC, parts with an MSL 3 rating require baking prior to soldering, if the part is not kept in a continuously dry (< 10% RH) environment before assembly. Reference IPC/JEDEC standard J-STD-033 for additional information.

No special reflow profile is required for QMC5883L, which is compatible with lead eutectic and lead-free solder paste reflow profiles. QST recommends adopting solder paste manufacturer's guidelines. Hand soldering is not recommended.

### 7.4.3 External Capacitors

The external capacitors C1 should be ceramic type with low ESR characteristics.

The exact ESR value is not critical, but values less than 200 milli-ohms are recommended.

Reservoir capacitor C1 is nominally 4.7 µF in capacitance. Low ESR characteristics may not be in many small SMT ceramic capacitors (0402), so be prepared to up-size the capacitors to gain low ESR characteristics.

## 8. Basic Device Operation

### 8.1 Anisotropic Magneto-Resistive Sensors

The QMC5883L magneto-resistive sensor circuit consists of tri-axial sensors and application specific support circuits to measure magnetic fields. With a DC power supply is applied to the sensor two terminals, the sensor converts any incident magnetic field in the sensitive axis directions to a differential voltage output. The ASIC then amplifies and processes the signal to have a digital output.

The device has an offset cancellation function to eliminate sensor and ASIC offsets.

It also applies a self-aligned magnetic field to restore magnetic state before each measurement to ensure high accuracy. Because of these features, the QMC5883L doesn't need to calibrate every time in most of application situations. It may need to be calibrated once in a new system or a system changes a new battery.

### 8.2 Power Management

There are two power supply pins to the device. VDD provides power for all the internal analog and digital functional blocks. VDDIO provides power for digital I/O and logic. It is possible to work with VDDIO equal to VDD, the single supply mode, or with VDDIO lower than VDD, the dual supply mode.

The device should turn-on both power pins in order to operate properly. When the device is powered on, all registers are reset by POR, then the device transits to the standby mode and waits for further commands.

Table 6 provides references for four power states. Transitions between power state 2 and power state 3 are prohibited, due to leakage current concerns.

**Table 6: Power States**

| Power State | VDD        | VDDIO      | Power State description  |
|-------------|------------|------------|--|
| 1           | 0V         | 0V         | Device Off, No Power Consumption                                       |
| 2           | 0V         | 1.65v~3.6v | Device Off, Unpredictable Leakage Current on VDD due to Floating Node. |
| 3           | 2.16v~3.6v | 0          | Device Off, Same Current as Standby Mode                               |
| 4           | 2.16v~3.6v | 1.65v~3.6v | Device On, Normal Operation Mode, Enters Standby Mode after POR        |

### 8. Basic Device Operation

#### 8.3 Power On/Off Time

After the device is powered on, some time periods are required for the device fully functional. The external power supply requires a time period for voltage to ramp up (PSUP), it is typically 50 milli-second. However it isn't controlled by the device.

The Power -On -Reset time period (PORT) includes time to reset all the logics, load values in NVM to proper registers, enter the standby mode and get ready for analogy measurements.

The power on/off time related to the device is in Table 7.

Table 7. Time Required for Power On/Off

| Parameter           | Symbol | Condition   | Min. | Typ. | Max. | Unit |
|---------------------|--------|---|------|------|------|------|
| POR Completion Time | PORT   | Time Period After VDD and VDDIO at Operating Voltage to Ready for I <sup>2</sup> C Command and Analogy Measurement. |      |      | 350  | uS   |
| Power off Voltage   | SDV    | Voltage that Device Considers to be Power Down.   |      |      | 0.2  | V    |
| Power on Interval   | PINT   | Time Period Required for Voltage Lower Than SDV to Enable Next POR  | 100  |      |      | uS   |

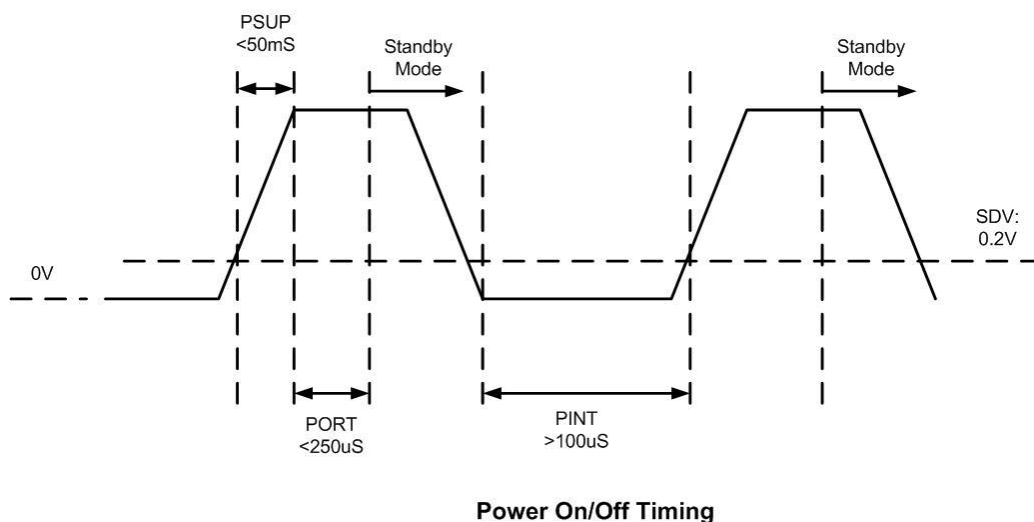

Figure 8. Power On/Off Timing

## 8.4 Communication Bus Interface I<sup>2</sup>C and Its Addresses

This device will be connected to a serial interface bus as a slave device under the control of a master device, such as the processor. Control of this device is carried out via I<sup>2</sup>C.

This device is compliant with I<sup>2</sup>C -Bus Specification, document number: 9398 393 40011.

As an I<sup>2</sup>C compatible device, this device has a 7-bit serial address and supports I<sup>2</sup>C protocols.

This device supports standard and fast speed modes, 100kHz and 400kHz, respectively.

External pull-up resistors are required to support all these modes.

The default I<sup>2</sup>C address is 0D: 0001101

If other I<sup>2</sup>C address options are required, please contact factory.

## 8.5 Internal Clock

The device has an internal clock for internal digital logic functions and timing management.

This clock is not available to external usage.

## 8.6 Temperature Compensation

Temperature compensation of the measured magnetic data is enabled by default at the factory.

Temperature measured by the built-in temperature sensor will be used to compensate the magnetic sensor's sensitivity changes due to temperatures. The compensated magnetic sensor data is placed in the Output Data Registers automatically.

## 8.7 Temperature Output

QMC5883L has a built-in temperature sensor, it can provide temperature reading for other applications. The output is placed in Temperature Output Registers (07H and 08H).

The temperature is calibrated for its sensitivity.

## 9. Modes Of Operation

### 9.1 Modes Transition

The device has two different operational modes, controlled by register (09H), mode bits. The main purpose of these modes is for power management. The modes can be transitioned from one to the other, as shown below, through I2C commands of changing mode bits.

The default mode is Standby.

Soft Reset could be set at any time and then chip automatically transits to standby mode

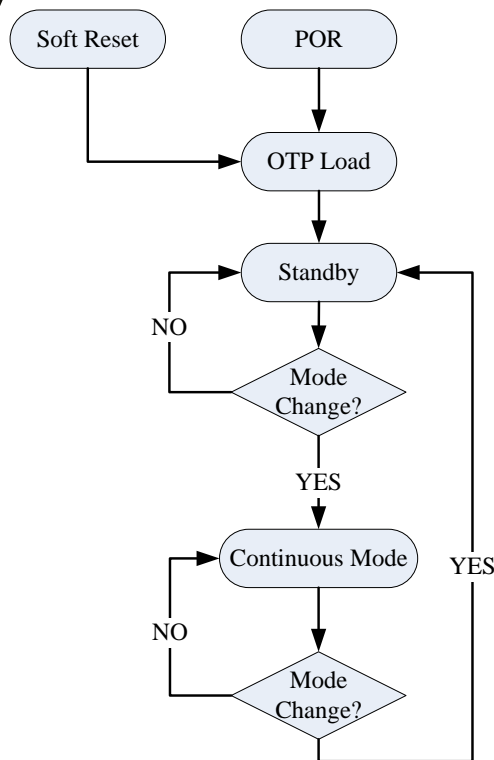

The system automatically transits to standby mode after power on reset or soft reset.

Figure 9. Modes Transition



### 9.2 Description of Modes

#### 9.2.1 Continuous-Measurement Mode

During the continuous-measurement mode (mode bits= 01), the magnetic sensor continuously makes measurements and places measured data in data output registers.

The field range (or sensitivity) and data output rate registers are also located in the control register (09H), they should be set up properly for your applications in the continuous-measurement mode.

For example, if the application requires output data rate 50Hz, the ODR bit in control register (09H) should be 01. If the field range is +/-8 Gauss, the RNG =01.

The over sample rate is optional for you to use. The default is OSR=00, if your application has enough resolution and need low power consumption, you may reduce OSR to a lower number, such as OSR=10 (128) or OSR =11 (64).

In the continuous-measurement mode, the magnetic sensor data are automatically compensated for offset and temperature effects. The gains are calibrated in the factory.

##### 9.2.1.1 Normal Read Sequence

Complete magnetometer data read-out can be done as follow steps.

- Check DRDY pin or by polling DRDY bit in Register 06H
- Read DRDY bit in Register 06H (if polling, it's unnecessary)

DRDY: Data ready ("1") or Not ("0").

DOR: Any data has been missed ("1") or not ("0")

- Read measured data, if any of the six data register is accessed, DRDY and DOR turn to "0".
- Data protection, if any of the six data register is accessed, data protection starts. During Data protection period, data register cannot be updated until the last bits 05H (ZOUT [15:8]) have been read.

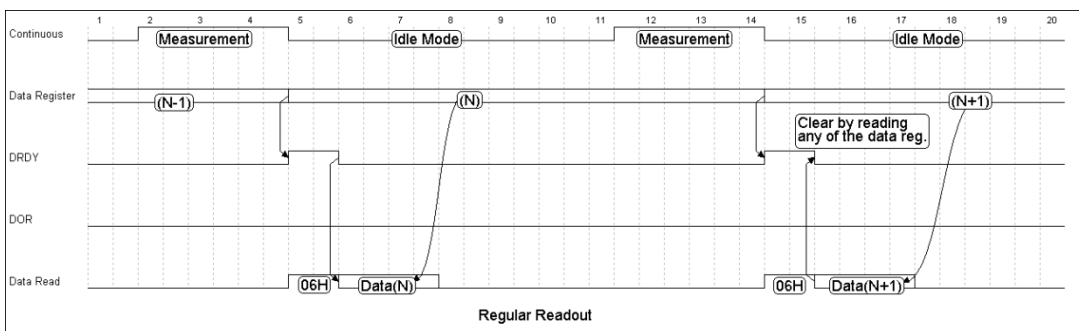

Figure 10. Normal Read Sequence

### 9.2.1.2 Data Read Sequence Occurs at Measurement

During measurement, it's possible to read data register which keep the previous measured data. Therefore, no interrupt (DRDY bit) will be set if data reading occurs at the middle of measurement.

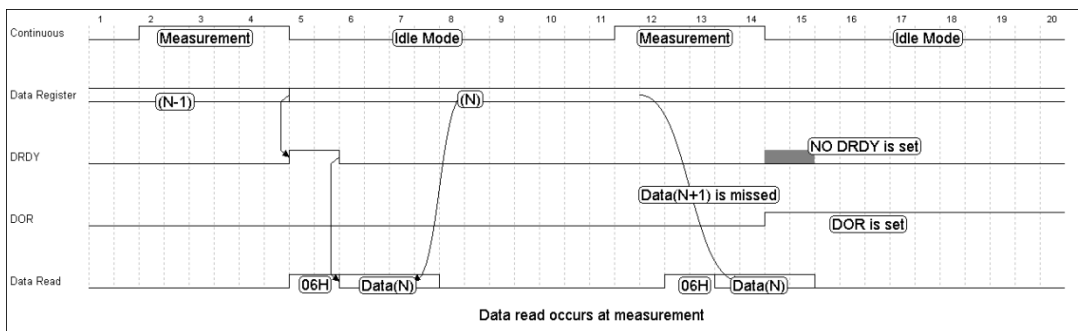

Figure 11 Data Read Sequence at Measurement

### 9.2.1.3 Data Not Read

If Nth data is skipped, the current data will be flushed by next coming data. In this case, interrupt (DRDY bit) keeps high until data is read. DOR bit is set to "1" which indicates a set of measurement data has been lost. DOR bit turns to "0" once 06H is accessed in next data read operation

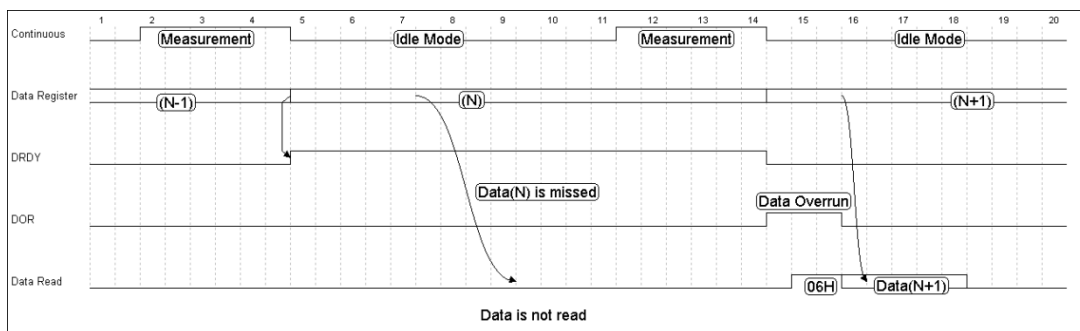

Figure 12. Sequence When Data Not Read

#### 9.2.1.4 Data Locks Until Next Measurement Ends

Data lock is activated once any of the data register is accessed. If 05H (data unlock) is not accessed until next measurements ends, current data blocks next data to update data register. In this case, DOR bit is also set to "1" until 06H is accessed in next data read.

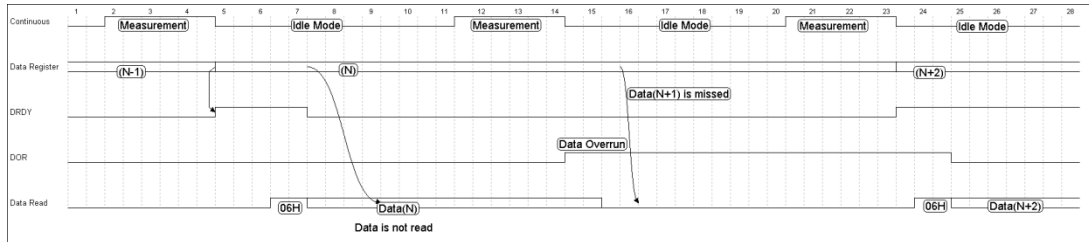

Figure 13. Sequence When Data Locks

#### 9.2.1.5 Interrupt

An interrupt is generated on DRDY pin each time that magnetic field is measured. The interrupt can be disabled by set 0AH[0] = 1.

#### 9.2.2 Standby Mode

Standby mode is the default state of QMC5883L upon POR and soft reset, only few function blocks are activated in this mode, which keeps power consumption as low as possible. In this state, register values are hold on by an ultra-low power LDO, I<sup>2</sup>C interface can be woken up by reading or writing any registers. There is no magnetometer measurement in the Standby mode. Internal clocking is also halted.

## 10. Application Examples

### 10.1 Continuous Mode Setup Example

- Write Register 0BH by 0x01 (Define Set/Reset period)
- Write Register 09H by 0x1D (Define OSR = 512, Full Scale Range = 8 Gauss, ODR = 200Hz, set continuous measurement mode)

### 10.2 Measurement Example

- Check status register 06H[0], "1" means ready.
- Read data register 00H ~ 05H.

### 10.3 Standby Example

- Write Register 09H by 0x00

### 10.4 Soft Reset Example

- Write Register 0AH by 0x80

### 11. I<sup>2</sup>C Communicatin Protocol

#### 11.1 I<sup>2</sup>C Timings

Below table and graph describe the I<sup>2</sup>C communication protocol times

Table 9. I2C Timings

| Parameter             | Symbol       | Condition | Min. | Typ. | Max. | Unit    |
|-----------------------|--------------|-----------|------|------|------|---------|
| SCL Clock             | $f_{scl}$    |           | 0    |      | 400  | kHz     |
| SCL Low Period        | $t_{low}$    |           | 1    |      |      | $\mu$ S |
| SCL High Period       | $t_{high}$   |           | 1    |      |      | $\mu$ S |
| SDA Setup Time        | $t_{suda}$   |           | 0.1  |      |      | $\mu$ S |
| SDA Hold Time         | $t_{hdadat}$ |           | 0    |      | 0.9  | $\mu$ S |
| Start Hold Time       | $t_{hdsta}$  |           | 0.6  |      |      | $\mu$ S |
| Start Setup Time      | $t_{susta}$  |           | 0.6  |      |      | $\mu$ S |
| Stop Setup Time       | $t_{susto}$  |           | 0.6  |      |      | $\mu$ S |
| New Transmission Time | $t_{buf}$    |           | 1.3  |      |      | $\mu$ S |
| Rise Time             | $t_r$        |           |      |      |      | $\mu$ S |
| Fall Time             | $t_f$        |           |      |      |      | $\mu$ S |

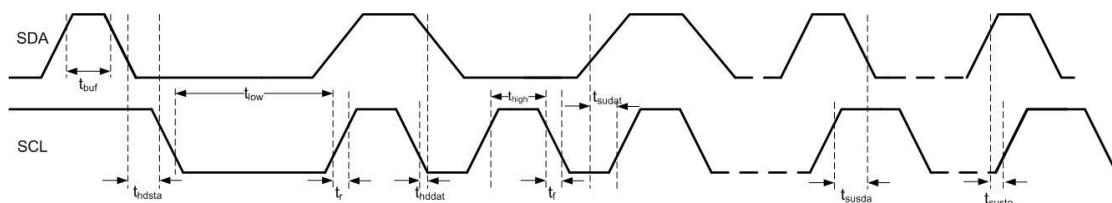

I<sup>2</sup>C Timing Diagram

Figure 14. I2C Timing Diagram

#### 11.2 I<sup>2</sup>C R/W Operation

##### 11.2.1 Abbreviation

Table 10. Abbreviation

|      |                            |
|------|----------------------------|
| SACK | Acknowledged by slave      |
| MACK | Acknowledged by master     |
| NACK | Not acknowledged by master |
| RW   | Read/Write                 |

### 11.2.2 Start/Stop/Ack

**START:** Data transmission begins with a high to transition on SDA while SCL is held high.

Once I<sup>2</sup>C transmission starts, the bus is considered busy.

**STOP:** STOP condition is a low to high transition on SDA line while SCL is held high.

**ACK:** Each byte of data transferred must be acknowledged. The transmitter must release the SDA line during the acknowledge pulse while the receiver must then pull the SDA line low so that it remains stable low during the high period of the acknowledge clock cycle.

**NACK:** If the receiver doesn't pull down the SDA line during the high period of the acknowledge clock cycle, it's recognized as NACK by the transmitter.

### 11.2.3 I<sup>2</sup>C Write

I<sup>2</sup>C write sequence begins with start condition generated by master followed by 7 bits slave address and a write bit (R/W=0). The slave sends an acknowledge bit (ACK=0) and releases the bus. The master sends the one byte register address. The slave again acknowledges the transmission and waits for 8 bits data which shall be written to the specified register address. After the slave acknowledges the data byte, the master generates a stop signal and terminates the writing protocol.

Table 11. I<sup>2</sup>C Write

| START | Slave Address |   |   |   |   |   |   | R<br>W | SACK | Register Address<br>(0x09) |   |   |   |   |   |   |   | SACK | Data<br>(0x01) |   |   |   |   |   |   |   | SACK | STOP |
|-------|---------------|---|---|---|---|---|---|--------|------|----------------------------|---|---|---|---|---|---|---|------|----------------|---|---|---|---|---|---|---|------|------|
|       | 0             | 0 | 0 | 1 | 1 | 0 | 1 | 0      |      | 0                          | 0 | 0 | 0 | 1 | 0 | 0 | 1 |      | 0              | 0 | 0 | 0 | 0 | 0 | 0 | 0 |      |      |
|       | 0             | 0 | 0 | 1 | 1 | 0 | 1 | 0      | 0    | 0                          | 0 | 0 | 1 | 0 | 0 | 1 | 0 | 0    | 0              | 0 | 0 | 0 | 0 | 1 |   |   |      |      |

### 11.2.4 I<sup>2</sup>C Read

I<sup>2</sup>C write sequence consists of a one-byte I<sup>2</sup>C write phase followed by the I<sup>2</sup>C read phase. A start condition must be generated between two phase. The I<sup>2</sup>C write phase addresses the slave and sends the register address to be read. After slave acknowledges the transmission, the master generates again a start condition and sends the slave address together with a read bit (R/W=1). Then master releases the bus and waits for the data bytes to be read out from slave. After each data byte the master has to generate an acknowledge bit (ACK = 0) to enable further data transfer. A NACK from the master stops the data being transferred from the slave. The slave releases the bus so that the master can generate a STOP condition and terminate the transmission.

The register address is automatically incremented and more than one byte can be sequentially read out. Once a new data read transmission starts, the start address will be set to the register address specified in the current I<sup>2</sup>C write command.

**Table 12. I<sup>2</sup>C Read**

|       |                |   |   |   |   |   |   |        |      |                            |   |   |   |   |   |   |   |      |                |   |   |   |   |   |   |   |      |      |
|-------|----------------|---|---|---|---|---|---|--------|------|----------------------------|---|---|---|---|---|---|---|------|----------------|---|---|---|---|---|---|---|------|------|
| START | Slave Address  |   |   |   |   |   |   | R<br>W | SACK | Register Address<br>(0x00) |   |   |   |   |   |   |   | SACK |                |   |   |   |   |   |   |   |      |      |
|       | 0              | 0 | 0 | 1 | 1 | 0 | 1 | 0      |      | 0                          | 0 | 0 | 0 | 0 | 0 | 0 | 0 |      |                |   |   |   |   |   |   |   |      |      |
| START | Slave Address  |   |   |   |   |   |   | R<br>W | SACK | Data<br>(0x00)             |   |   |   |   |   |   |   | MACK | Data<br>(0x01) |   |   |   |   |   |   |   |      |      |
|       | 0              | 0 | 0 | 1 | 1 | 0 | 1 | 1      |      | 0                          | 0 | 0 | 0 | 0 | 0 | 0 | 0 |      | 0              | 0 | 0 | 0 | 0 | 0 | 0 | 1 |      |      |
| MACK  | Data<br>(0x02) |   |   |   |   |   |   |        | MACK | .....<br>.....<br>.....    |   |   |   |   |   |   |   | MACK | Data<br>(0x07) |   |   |   |   |   |   |   | NACK | STOP |
|       | 0              | 0 | 0 | 0 | 0 | 0 | 1 | 0      |      |                            |   |   |   |   |   |   |   |      | 0              | 0 | 0 | 0 | 0 | 1 | 1 | 1 |      |      |

### 11.2.5 I<sup>2</sup>C Pointer Roll-over

QMC5883L has an embedded I<sup>2</sup>C pointer roll-over function which can improve the data transmission efficiency. The I<sup>2</sup>C data pointer will automatically roll between 00H ~ 06H if I<sup>2</sup>C read begins at any position among 00H~06H. This function is enabled by set 0AH[6] = 01H.

## 12. Registers

### 12.1 Register Map

The table below provides a list of the 8-bit registers embedded in the device and their respective function and addresses

**Table 13. Register Map**

| Addr. | 7                                     | 6        | 5        | 4 | 3        | 2   | 1         | 0        | Access                   |
|-------|---------------------------------------|----------|----------|---|----------|-----|-----------|----------|--------------------------|
| 00H   | Data Output X LSB Register XOUT[7:0]  |          |          |   |          |     |           |          | Read only                |
| 01H   | Data Output X MSB Register XOUT[15:8] |          |          |   |          |     |           |          | Read only                |
| 02H   | Data Output Y LSB Register YOUT[7:0]  |          |          |   |          |     |           |          | Read only                |
| 03H   | Data Output Y MSB Register YOUT[15:8] |          |          |   |          |     |           |          | Read only                |
| 04H   | Data Output Z LSB Register ZOUT[7:0]  |          |          |   |          |     |           |          | Read only                |
| 05H   | Data Output Z MSB Register ZOUT[15:8] |          |          |   |          |     |           |          | Read only                |
| 06H   |                                       |          |          |   |          | DOR | OVL       | DRDY     | Read only                |
| 07H   | TOUT[7:0]                             |          |          |   |          |     |           |          | Read only                |
| 08H   | TOUT[15:8]                            |          |          |   |          |     |           |          | Read only                |
| 09H   | OSR[1:0]                              |          | RNG[1:0] |   | ODR[1:0] |     | MODE[1:0] |          | Read/Write               |
| 0AH   | SOFT_ RST                             | ROL_P NT |          |   |          |     |           | INT_E NB | R/W, Read only on blanks |
| 0BH   | SET/RESET Period FBR [7:0]            |          |          |   |          |     |           |          | Read/Write               |
| 0CH   | Reserved                              |          |          |   |          |     |           |          | Read only                |
| 0DH   | Reserved                              |          |          |   |          |     |           |          | Read only                |

## 12.2 Register Definition

### 12.2.1 Output Data Register

Registers 00H ~ 05H store the measurement data from each axis magnetic sensor in continuous-measurement. In the continuous measurement mode, the output data is refreshed periodically based on the data update rate ODR setup in control registers 1. The data stays the same, regardless of reading status through I<sup>2</sup>C, until new data replaces them. Each axis has 16 bit data width in 2's complement, i.e., MSB of 01H/03H/05H indicates the sign of each axis. The output data of each channel saturates at -32768 and 32767.

**Table 14. Output Data Register**

| Addr. | 7                                     | 6 | 5 | 4 | 3 | 2 | 1 | 0 |
|-------|---------------------------------------|---|---|---|---|---|---|---|
| 00H   | Data Output X LSB Register XOUT[7:0]  |   |   |   |   |   |   |   |
| 01H   | Data Output X MSB Register XOUT[15:8] |   |   |   |   |   |   |   |
| 02H   | Data Output Y LSB Register YOUT[7:0]  |   |   |   |   |   |   |   |
| 03H   | Data Output Y MSB Register YOUT[15:8] |   |   |   |   |   |   |   |
| 04H   | Data Output Z LSB Register ZOUT[7:0]  |   |   |   |   |   |   |   |
| 05H   | Data Output Z MSB Register ZOUT[15:8] |   |   |   |   |   |   |   |

### 12.2.2 Status Register

There are two status registers located in address 06H and 0CH.

Register 06H has three bits indicating for status flags, the rest are reserved for factory use.

The status registers are read only bits.

**Table 15. Status Register 1**

| Addr. | 7 | 6 | 5 | 4 | 3 | 2   | 1   | 0    |
|-------|---|---|---|---|---|-----|-----|------|
| 06H   |   |   |   |   |   | DOR | OVL | DRDY |



Data Ready Register (DRDY), it is set when all three axis data is ready, and loaded to the output data registers in the continuous measurement mode. It is reset to "0" by reading any data register (00H~05H) through I<sup>2</sup>C commands

DRDY: "0": no new data, "1": new data is ready

Overflow flag (OVL) is set to "1" if any data of three axis magnetic sensor channels is out of range. The output data of each axis saturates at -32768 and 32767, if any of the axis exceeds this range, OVL flag is set to "1". This flag is reset to "0" if next measurement goes back to the range of (-32768, 32767), otherwise, it keeps as "1".

OVL: "0": normal, "1": data overflow

Data Skip (DOR) bit is set to "1" if all the channels of output data registers are skipped in reading in the continuous-measurement mode. It is reset to "0" by reading any data register (00H~05H) through I<sup>2</sup>C.

DOR: "0": normal, "1": data skipped for reading

### 12.2.3 Temperature Data Registers

Registers 07H-08H store temperature sensor output data. 16 bits temperature sensor output is in 2's complement. Temperature sensor gain is factory-calibrated, but its offset has not been compensated, only relative temperature value is accurate. The temperature coefficient is about 100 LSB/°C

Table 17. Temperature Sensor Output

| Addr. | 7          | 6 | 5 | 4 | 3 | 2 | 1 | 0 |
|-------|------------|---|---|---|---|---|---|---|
| 07H   | TOUT[7:0]  |   |   |   |   |   |   |   |
| 08H   | TOUT[15:8] |   |   |   |   |   |   |   |

### 12.2.4 Control Registers

Two 8-bits registers are used to control the device configurations.

Control register 1 is located in address 09H, it sets the operational modes (MODE), output data update rate (ODR), magnetic field measurement range or sensitivity of the sensors (RNG) and over sampling rate (OSR). Control register 2 is located in address 0AH. It controls Interrupt Pin enabling (INT\_ENB), Point roll over function enabling (POL\_PNT) and soft reset (SOFT\_RST).

Two bits of MODE registers can transfer mode of operations in the device, the two modes are Standby, and Continuous measurements. The default mode after Power-on-Reset (POR) is standby. There is no any restriction in the transferring between the modes.

Output data rate is controlled by ODR registers. Four data update frequencies can be selected: 10Hz, 50Hz, 100Hz and 200Hz. For most of compassing applications, we recommend 10 Hz for low power consumption. For gaming, the high update rate such as 100Hz or 200Hz can be used.

Field ranges of the magnetic sensor can be selected through the register RNG. The full scale field range is determined by the application environments. For magnetic clear environment, low field range such as +/- 2 gauss can be used. The field range goes hand in hand with the sensitivity of the magnetic sensor. The lowest field range has the highest sensitivity, therefore, higher resolution.

Over sample Rate (OSR) registers are used to control bandwidth of an internal digital filter. Larger OSR value leads to smaller filter bandwidth, less in-band noise and higher power consumption. It could be used to reach a good balance between noise and power. Four over sample ratio can be selected, 64, 128, 256 or 512.

**Table 18. Control Register 1**

| Addr        | 7                 | 6      | 5         | 4          | 3         | 2         | 1         | 0 |
|-------------|-------------------|--------|-----------|------------|-----------|-----------|-----------|---|
| 09H         | OSR[1:0]          |        | RNG[1:0]  |            | ODR[1:0]  |           | MODE[1:0] |   |
| <b>Reg.</b> | <b>Definition</b> |        | <b>00</b> | <b>01</b>  | <b>10</b> | <b>11</b> |           |   |
| Mode        | Mode Control      |        | Standby   | Continuous | Reserve   | Reserve   |           |   |
| ODR         | Output Data Rate  |        | 10Hz      | 50Hz       | 100Hz     | 200Hz     |           |   |
| RNG         | Full Scale        |        | 2G        | 8G         | Reserve   | Reserve   |           |   |
| OSR         | Over              | Sample | 512       | 256        | 128       | 64        |           |   |
|             | Ratio             |        |           |            |           |           |           |   |

Interrupt enabling is controlled by register INT\_ENB in control register 2. Once the interrupt is enabled, it will flag when new data is in Data Output Registers.

INT\_ENB: "0": enable interrupt PIN, "1": disable interrupt PIN

Pointer roll-over function is controlled by ROL\_PNT register. When the point roll-over function is enabled, the I2C data pointer automatically rolls between 00H ~ 06H, if I<sup>2</sup>C read begins at any address among 00H~06H.

ROL\_PNT: "0": Normal, "1": Enable pointer roll-over function

Soft Reset can be done by changing the register SOFT\_RST to set. Soft reset can be invoked at any time of any mode. For example, if soft reset occurs at the middle of continuous mode reading, QMC5883L immediately switches to standby mode due to mode register is reset to "00" in default.

SOFT\_RST: "0": Normal "1": Soft reset, restore default value of all registers.

Table 19. Control Register 2

| Addr. | 7        | 6       | 5 | 4 | 3 | 2 | 1 | 0       |
|-------|----------|---------|---|---|---|---|---|---------|
| 0AH   | SOFT_RST | ROL_PNT |   |   |   |   |   | INT_ENB |

### 12.2.5 SET/RESET Period Register

SET/RESET Period is controlled by FBR [7:0], it is recommended that the register OBH is written by 0x01.

Table 20. SET/RESET Period Register

| Addr. | 7                          | 6 | 5 | 4 | 3 | 2 | 1 | 0 |
|-------|----------------------------|---|---|---|---|---|---|---|
| 0BH   | SET/RESET Period FBR [7:0] |   |   |   |   |   |   |   |

## 13. Caution

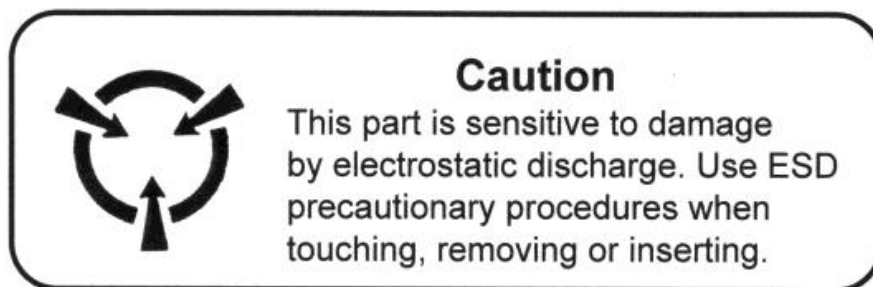

**CAUTION: ESDS CAT. 1B**