

M5StickC PLUS2

SKU:K016-P2



Description

M5StickC PLUS2 is an iterative version of M5StickC PLUS, featuring the ESP32-PICO-V3-02 chip as the main controller with built-in WiFi functionality. The compact device integrates a wealth of hardware resources within its small form factor, including infrared, RTC, microphone, LED, IMU, buttons, buzzer, and more. It boasts a 1.14-inch TFT screen with a resolution of 135*240, driven by the ST7789V2. The battery capacity has been increased to 200mAh, and the interface also supports HAT and Unit series products. This compact and versatile development tool is designed to spark limitless creative possibilities.

M5StickC PLUS2 facilitates the rapid prototyping of IoT products, streamlining the entire development process. Even beginners in programming can easily build interesting applications and apply them to real-life scenarios using M5StickC PLUS2.

Power on:

Wake up can be started by pressing "BUTTON C" for more than 2 seconds, or IRQ signal triggered by RTC regularly. After triggering the wake up signal, the hold(G4) pin needs to be set to a high level (1) in program initialization to maintain the power supply, otherwise the device will enter the shutdown state again.

Power off:

When no USB external power supply is available, press BUTTON C for more than 6 seconds. Or when there is no USB external power supply, set HOLD(GPIO4)=0 in the program operation, that is, to achieve power off. When the USB is connected, press the "BUTTON C" button for more than 6 seconds to turn off the screen and enter the hibernation state, but not power off.

Tutorial

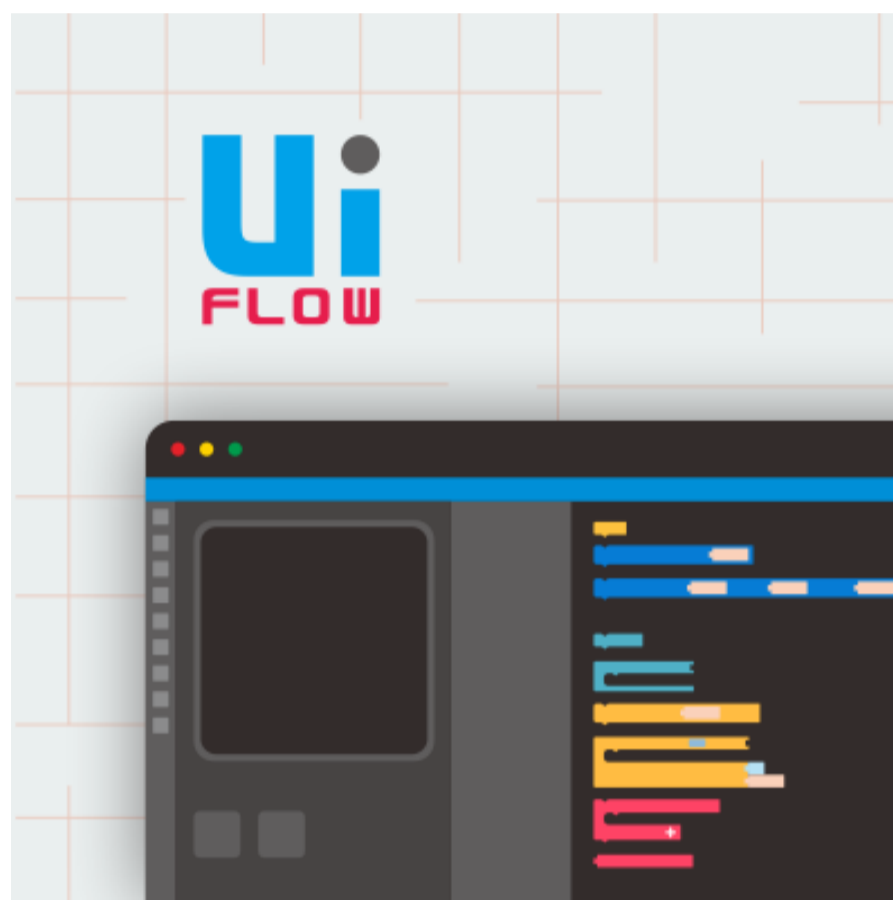

UIFlow

This tutorial will show you how to control M5StickC PLUS2 devices through the UIFlow graphical programming platform



Arduino IDE

This tutorial will show you how to program and control M5StickC PLUS2 devices through Arduino IDE

Features

- ESP32-PICO-V3-02-Base, support WiFi
- Built-in 6-Axis IMU
- IR transmitter
- Microphone
- RTC
- Buttons, LCD(1.14 inch)
- Built-in Lithium Polymer Battery@200mAh
- Extendable Socket
- Built-in Passive Buzzer
- Wearable & Wall mounted
- Compatible with multi-platform development:
 - [UIFlow](#)
 - [MicroPython](#)
 - [Arduino](#)

| Includes

- 1x M5StickC Plus2

| Applications

- Internet of things terminal controller
- Wearable devices
- Stem education product
- DIY creation

| Specification

Resources	Parameters
ESP32	ESP32-PICO-V3-02 240MHz dual core,support wifi,2 MB SPI PSRAM,8 MB SPI flash
PSRAM	2 MB PSRAM
Flash	8 MB flash
Power Input	5V @ 500mA
Port	TypeC x 1, GROVE(I2C+I/O+UART) x 1
LCD screen	1.14 inch, 135*240 Colorful TFT LCD, ST7789v2
Button	Custom button x 3
Power indicator LED	GREEN LED(non-programmable)
MEMS	MPU6886
Buzzer	built-in buzzer

MIC	SPM1423
RTC	BM8563
Battery	200mAh @ 3.7V
Antenna	2.4G 3D Antenna
PIN port	G0, G25/G36, G26, G32, G33
Operating Temperature	0°C to 60°C
Case Material	Plastic (PC)
Product Size	48*25*13mm
Package Size	114*64*23mm
Product Weight	17g
Package Weight	24.8g

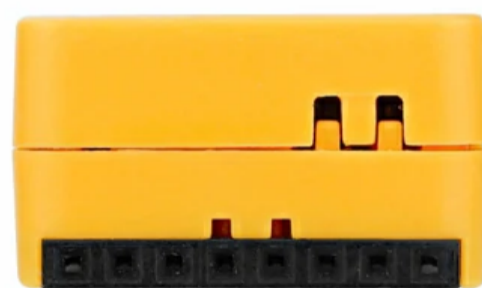
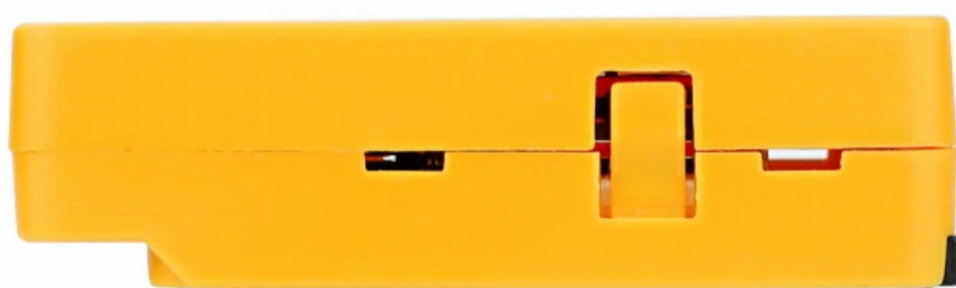

Driver Installation

Click the link below to download the driver that matches the operating system. There are currently two driver chip versions, CP34X (for **CH9102**) driver compressed package. After decompressing the compressed package, select the installation package corresponding to the number of operating systems to install. If the program cannot be downloaded normally (the prompt is overtime or Failed to write to target RAM), you can try to reinstall the device driver.

Driver name	Applicable driver chip	Download link
CH9102_VCP_SER_Windows	CH9102	Download
CH9102_VCP_SER_MacOS v1.7	CH9102	Download

EasyLoader

EasyLoader is a concise and fast program writer, which has a built-in case program related to the product. It can be burned to the main control by simple steps to perform a series of function verification.

[Download Windows Version Easyloader](#)

PinMap

RED LED & IR Transmitter & BUTTON A & BUTTON B

ESP32	GPIO19	GPIO37	GPIO39	GPIO35	GPIO2
IR Transmitter	Transmitter Pin				

BUTTON		Button			
A		Pin			
BUTTON			Button		
B			Pin		
BUTTON				Button	
C				Pin	
Buzzer					Buzzer
TFT LCD					Pin

Driver IC:ST7789v2

Resolution:135 * 240

ESP32	GPIO15	GPIO13	GPIO14	GPIO12	GPIO5
TFT LCD	TFT_MOSI	TFT_CLK	TFT_DC	TFT_RST	TFT_CS

GROVE PORT

ESP32	GPIO22	GPIO21	5V	GND
GROVE port	SCL	SDA	5V	GND

MIC (SPM1423)

ESP32	GPIO0	GPIO34
MICROPHONE	CLK	DATA

6-Axis posture sensor (MPU6886)

ESP32	GPIO22	GPIO21
6-Axis IMU sensor	SCL	SDA

Related Link

- ESP32-PICO-V3-02
- ST7789v2
- BM8563
- MPU6886
- SPM1423

Schematic

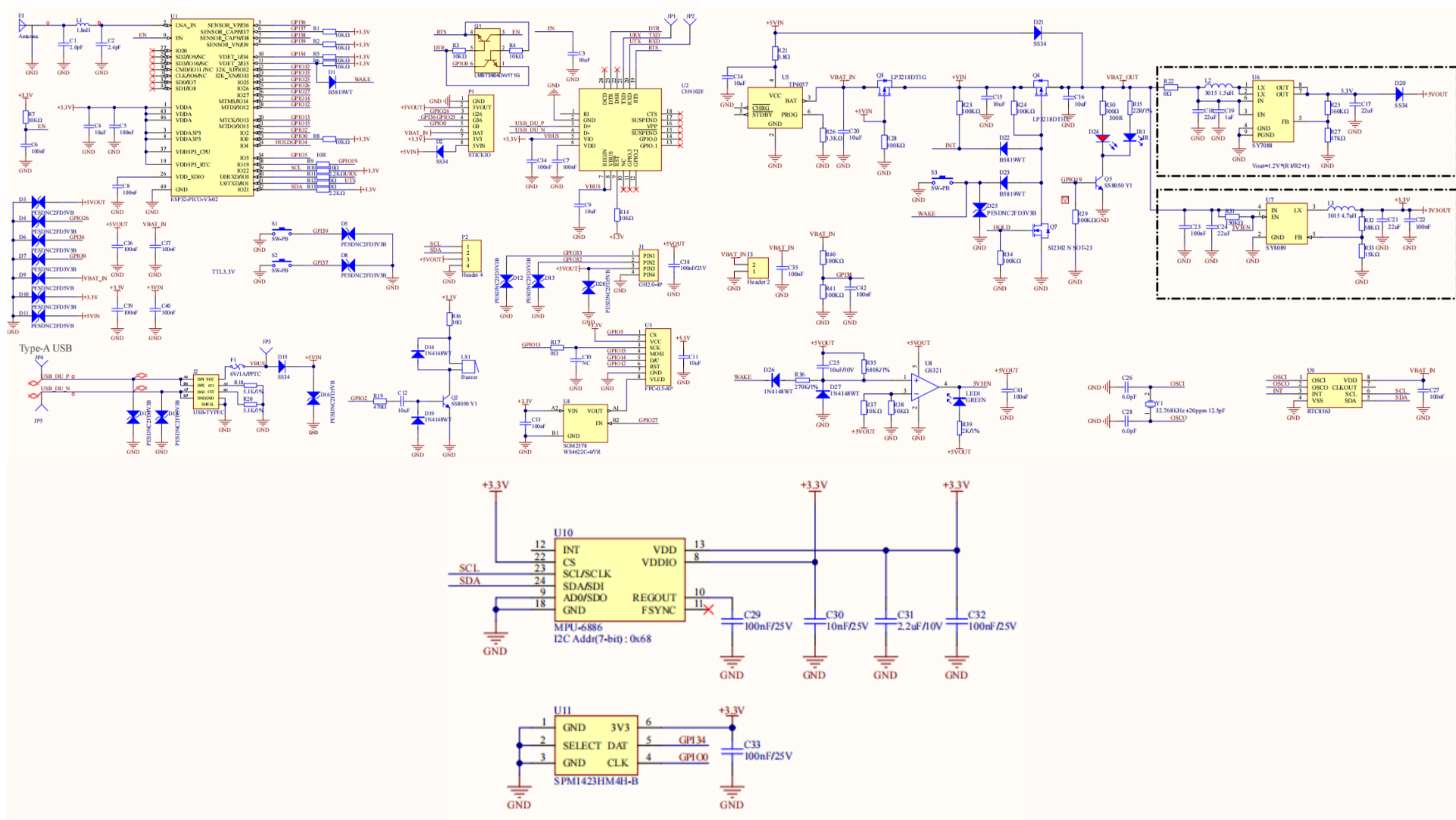

- [Schematic download](#)

Examples

Arduino

- [M5StickC_PLUS2 Library](#)
- [M5StickC_PLUS2 Factory Test Firmware](#)

Module Size

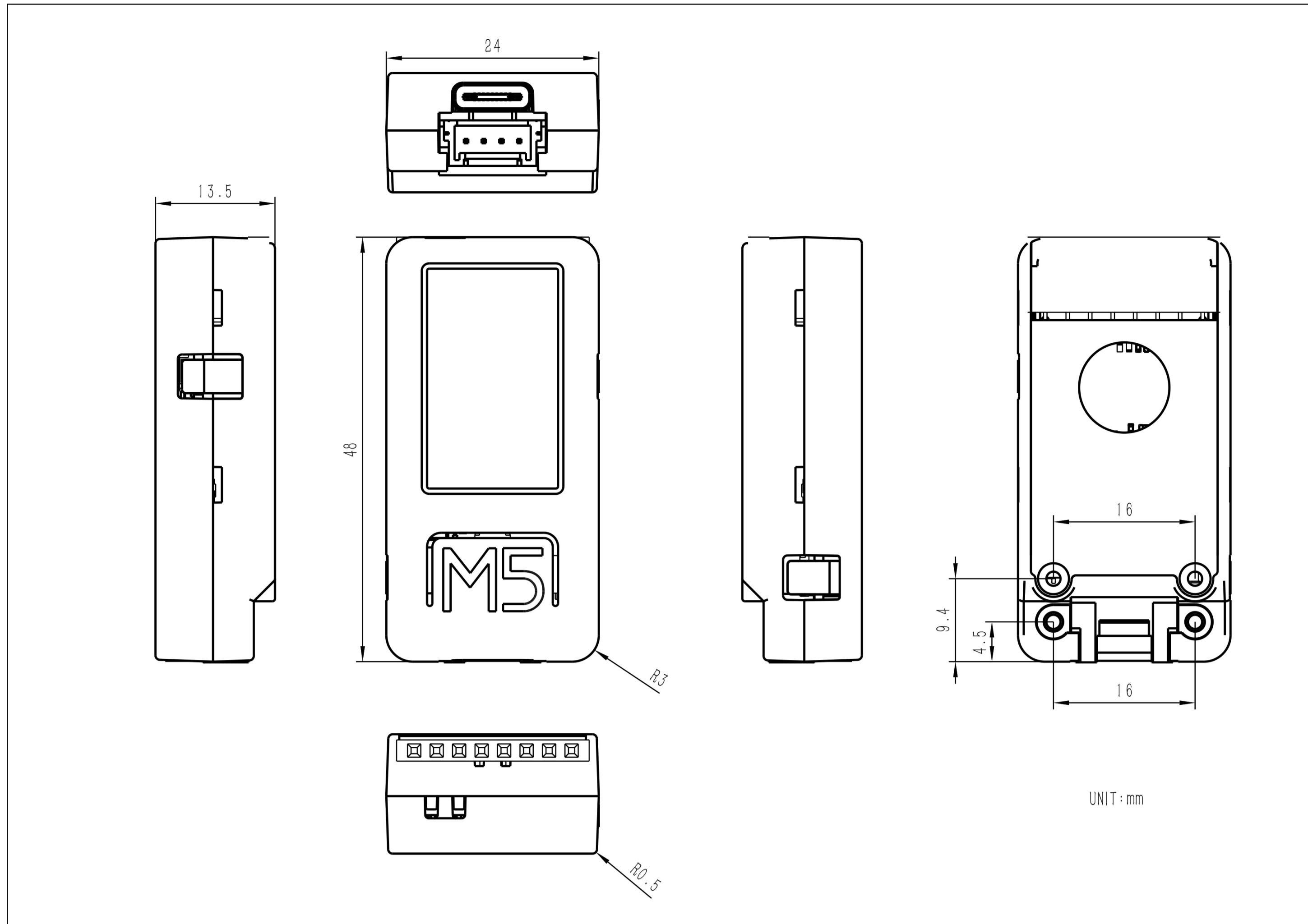

Version Change

Release Date	Product Change	Note:
/	Initial public release	/
2021.12	Added hibernation and wake-up functions, and changed version to v1.1	/
2023.12	The power management chip AXP192 was cancelled, and the main control chip was changed from ESP32-PICO-D4 to ESP32-PICO-V3-02, and the switching mode was different	The version is changed to v2

The difference between M5StickC PLUS and M5StickC PLUS2



Hardware difference

Product Name	SoC	Power management	Battery Capacity	Memory	UART Chip	Body Color
M5STICKC PLUS	ESP32-PICO-D4	AXP192	120mAh	520KB SRAM and 4MB Flash	CH522	orange red
M5STICKC PLUS2	ESP32-PICO-V3-02	\	200mAh	2MB PSRAM and 8MB flash	CH9102	orange

Pin difference

Product Name	IR	LED	TFT	BUTTON A	BUTTON B	BUTTON C(WAKE)
M5STIC KC PLUS	G9	G10	MOSI(G15) CLK(G13) DC(G23) RST(G18) CS(G5)	G37	G39	Normal buttons, non-programmable
M5STIC KC PLUS2	G19	G19	MOSI(G15) CLK(G13) DC(G14) RST(G12) CS(G5)	G37	G39	G35

The difference between turn on and off

Product Name	Power on	Power off
M5STIC KC PLUS	Press the reset BUTTON (BUTTON C) for at least 2 seconds	Press the reset BUTTON (BUTTON C) for at least 6 seconds
M5STIC KC PLUS2	<p>It can be started by pressing "BUTTON C" for more than 2 seconds, or IRQ signal triggered by RTC regularly.</p> <p>After triggering the wake up signal, it is necessary to set the hold(G4) pin to high level (1) in program initialization to maintain the power supply, otherwise the device will enter the shutdown state again.</p>	<p>When no USB external power supply is available, press BUTTON C for more than 6 seconds. Or when there is no USB external power supply, set HOLD(GPIO4)=0 in the program operation, that is, to achieve power off. When the USB is connected, press the "BUTTON C" button for more than 6 seconds to turn off the screen and enter the hibernation state, but not power off.</p>

Since M5StickC PLUS2 has cancelled the PMIC power management chip AXP192, the switching mode will be different. As mentioned in the beginning of the article, the operation is the same, so the library files supported by the program will also be different. Both the Wi-Fi signal and the infrared signal are stronger than before.

Video

Mouser Electronics

Authorized Distributor

Click to View Pricing, Inventory, Delivery & Lifecycle Information:

[M5Stack:](#)

[K016-P2](#)